

# SPECIFICATION FOR APPROVAL

**CUSTOMER:**

**Product Type:**

Toroidal waterproof transformer

**Model No:**

200W

**Date:**

2023.3.1

## Document revision record

frequency	Revised version	Reviser	Amendment	modification date

KRECO

Customer's approval

Approved by

Checked by

Drawn by

Hong

Hong

Hang

一、 Enforce Standard

Safety Standard: EN61558□

二、 Circuit Diagram

Circuit Diagram

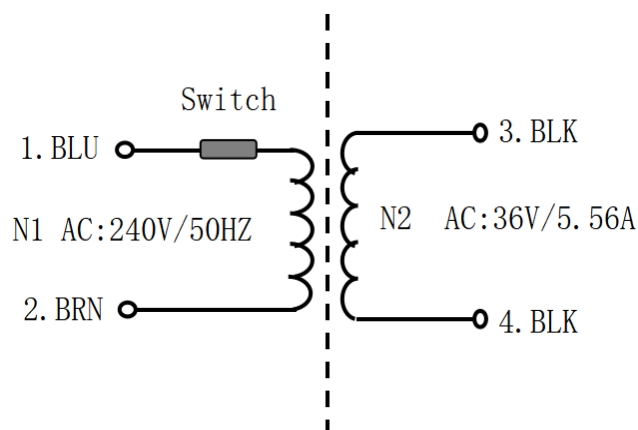

三、 Electrical Performances

1、 Primary rated Input: 0~240V AC 50Hz ±10%

2.Primary Exciting Current MAX: 70mA while Rated Input 240V/50HZ . The real value tested on the sample is 50MA

3、 Secondary rated voltage and current:

Winding NO.	Leads Color	(±2%) No Load Voltage	(±2%) Load Voltage	loaded Current
(2):3~4	BLK~BLK	0V~38.82V	36V	5.56A

4、 Temperature Rise Test:

Test circumstance : Ambient temperature 25°C Tested by means of resistant method

Test qualification: rated loading for 4 hours Max temperature rise of Primary and Secondary winding /60°C

5、 test result:

temperature rise of Primary and Secondary windings is under /50°C

四. Insulation

Main test equipments:

1. HI-POT METER: LK2670AX      2. INSULATION-RESISTANCE METER: VG2679

3. VOL TMETER : GDW4011      4. AMPEREMETER: GDW4011

Test Items	Test Conditions
Hi-Pot Test	4KV/3mA/2S Primary and Secondary Not break down
Insulation Resistance	Primary to Secondary 500VDC 100MΩ Min.
Short-Circuit of winding turn	While PRI: 2500V AC , Primary and Secondary has no break down

五. Product Protection

1、Electrostatic Shield  2、Magnetic Shield

3、Temperature Protection  4、Over Current Protection

六. External view dawg

External view dawg:

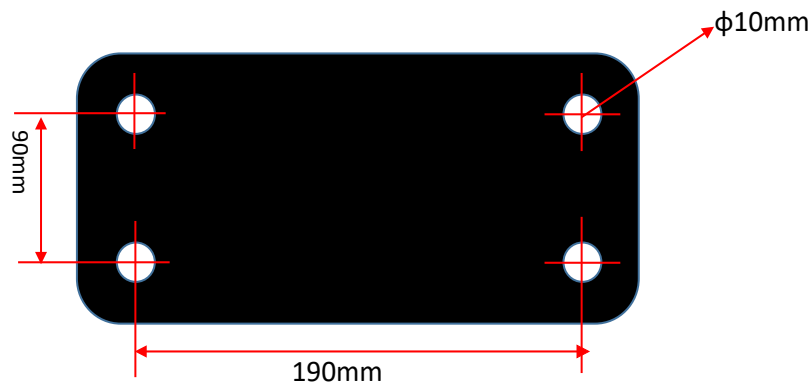
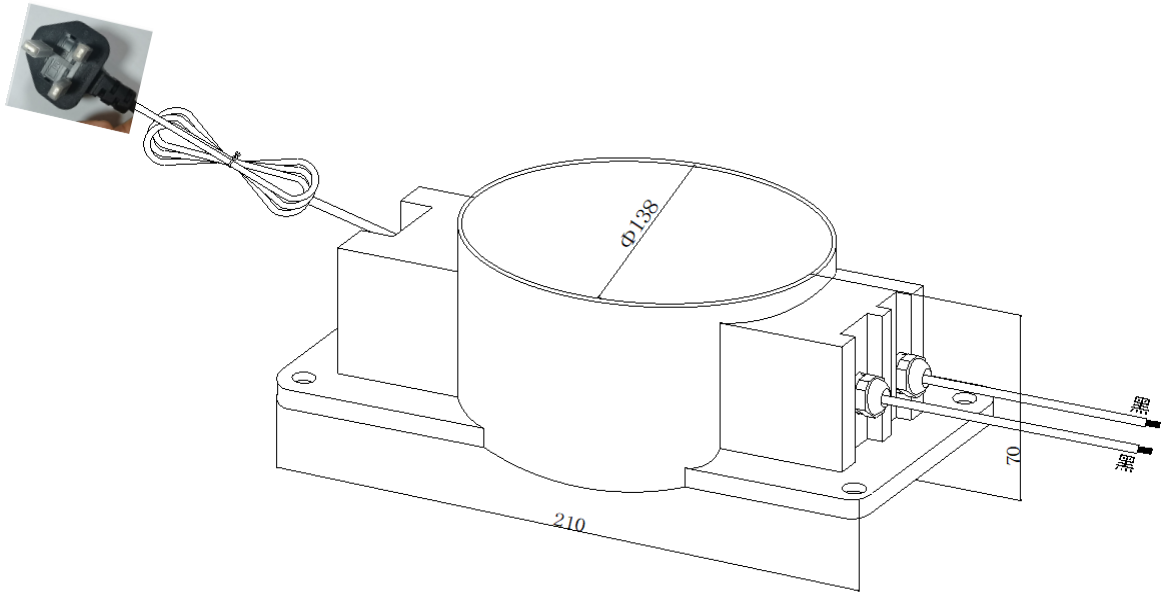

Dimensions: length  $\leq 210\text{mm}$ , Width  $\leq 138\text{mm}$ , Height  $\leq 70\text{mm}$

Finished unit Weight:

七. Leads

Winding NO.	Lead Color	Lead Type	Lead long	terminal
(1):1~2	BLK (BLU~BRN)	PVC-F 3*0.75	2000mm	UK 3 plug
(2):3~4	BLK~BLK	UL1015#/14AWG	3000mm	6mm tin solder

八./Label and Accessorise

Label	Accessorise				
	No.	Accessorise Name	Accessorise spec	Unit	Quantity
	1				
	2				
	3				
	4				
	5				
	6				

## 九、 CONSTRUCTION & MATERIAL LIST

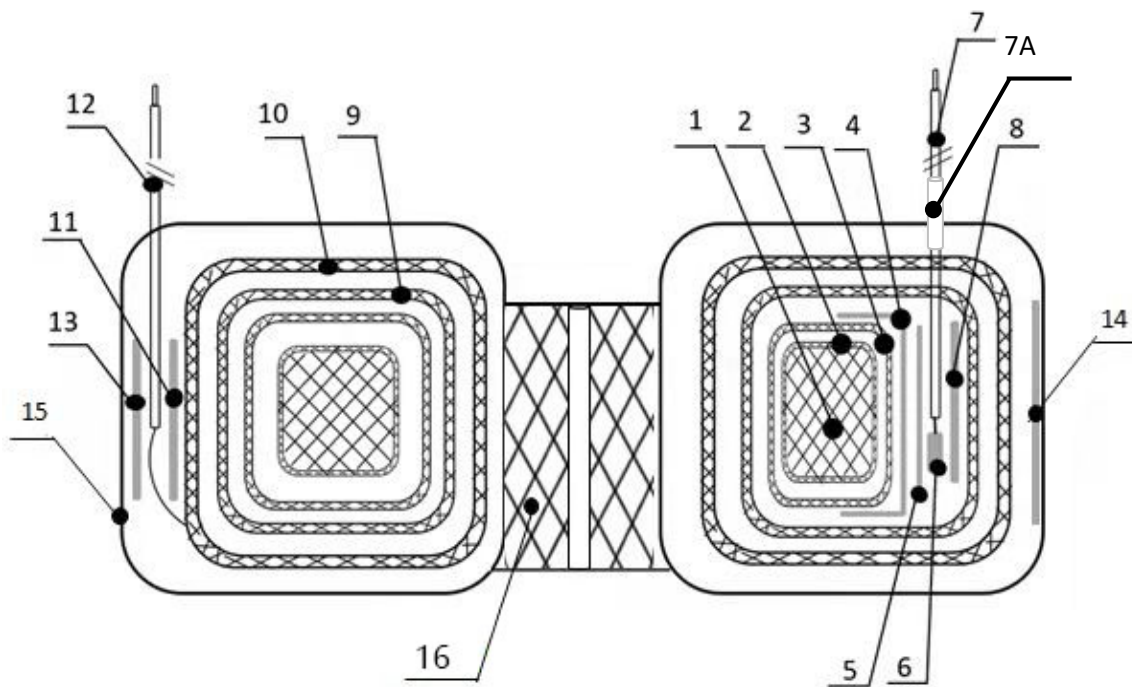

/No.	DENOMINATION	MATERIAL	MATERIAL TYPE	MANUFACTURER	CERTIFICATION NO.
1	Ring core	Oriented silicon steel strip	27Z120	Nippon Steel Corp or other equivalent suppliers	
2	Ring core insulation	Mylar	WC22	DUPONT TEIJIN FILMS U S L P	E93687
3	Primary winding	Enameled wire	Q(ZY/XY)L-2/220	Xuchang The Yellow Sea Electrician Co Ltd	E500578
4	Lead pad	Mylar	WC22	DUPONT TEIJIN FILMS U S L P	E93687
5	Joint bottom pad	Mylar	WC22	DUPONT TEIJIN FILMS U S L P	E93687
6	Safety device	Thermal switch	BW-BCP/130	SAFTTY ELECTRONIC TECHNOLOGY CO LTD	E336150
7	Primary lead	UL electronic certification line	PVC-F 3*0.75	YUYAO JINGYI ELECTRONICS CO LTD	E231324
7A	Fibre sleeve	YONGTENG180-1	2753	XUCHANG YONGTENG INSULATION MATERIAL CO LTD	E508986
8	Joint upper pad	Mylar	WC22	DUPONT TEIJIN FILMS U S L P	E93687
9	Primary winding insulation	Mylar	WC22	DUPONT TEIJIN FILMS U S L P	E93687
10	Secondary winding	Enameled wire	Q(ZY/XY)L-2/220	Xuchang The Yellow Sea Electrician Co Ltd	E500578
11	Joint bottom pad	Mylar	WC22	DUPONT TEIJIN FILMS U S L P	E93687
12	Secondary lead	UL electronic certification line	1015#/14AWG	Xin Sheng Terminal Mfg Ltd	E328303
13	Joint upper pad	Mylar	WC22	DUPONT TEIJIN FILMS U S L P	E93687
14	Protective tape	PET films with acrylic adhesive	HMT804	SHEN ZHEN XINHUAHUI ELECTRONIC MATERIALS CO LTD	E328315
15	External insulation	Mylar	WC22	DUPONT TEIJIN FILMS U S L P	E93687
16	Potting glue	epoxy Casting Compound	3300A/B	DONGGUAN EATTO ELECTRONIC MATERIAL CO LTD	E218090
17	Case	PP+GFRP	PP202T PP301-G20	DAFA factory chancheng Distrit FOSHAN or equivalent	