

顾客:  
CUSTOMER

140062

FILE NO:

A版

文件编号:



景荣企业有限公司  
中山市景荣电子有限公司

KINGRONG ENTERPRISE LTD. (Since 2008)

ZHONGSHAN KINGRONG ELECTRONICS CO., LTD.

## 样品承认书

# SPECIFICATION FOR APPROVAL

产品名称 \_\_\_\_\_ 型号 \_\_\_\_\_  
DESCRIPTION TOROIDAL TRANSFORMER MODEL NO 50-16

顾客部品号 \_\_\_\_\_  
CUSTOMER'S PART NO.

制造商料号 \_\_\_\_\_ 日期 \_\_\_\_\_  
MANUFACTURE'S P/N. KRE23016-50 DATE 2023年3月24日

确认签字、盖章后请寄回此承认书一份

PLEASE RETURN TO US ONE COPY OF "SPECIFICATION  
FOR APPROVAL " WITH YOUR APPROVED SIGNATURES

	"√"	顾客签名 CUSTOMER'S SIGNATURE	备注 NOTE
完全承认 FULL APPROVED			
有条件承认 CONDITIONAL APPROVED			
不予承认 REJECTED			

ZHONGSHAN KINGRONG ELECTRONICS CO.,LTD.

9/F,Block 2,Bldg 6 Meicheng Creative Industrial Park,Mingcheng East Rd,

Xiaolan,Zhongshan,Guangdong,528415 China

MOBILE:+86-13822715268 TEL:+86-760-22582166

EMAIL: SALES@KRECO.COM.CN

顾客 CUSTOMER	140062	产品名称 DESCRIPTION	TRANSFORMER	
部品号 KRECO P/N	KRE23016-50	型号 MODEL	50-16	A版

1. 外形图 (单位:mm)  
DIMENSION (UNIT:mm)

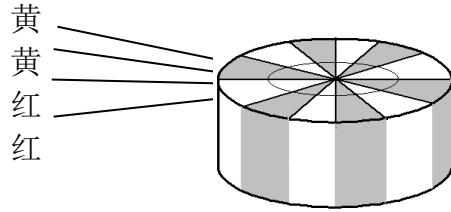

外包白色玛拉胶, 透明带。

**LABEL:**

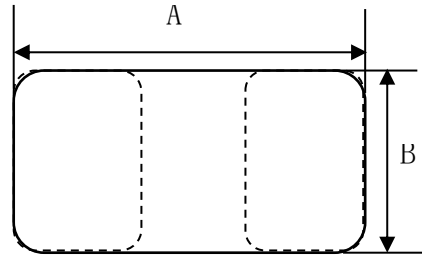
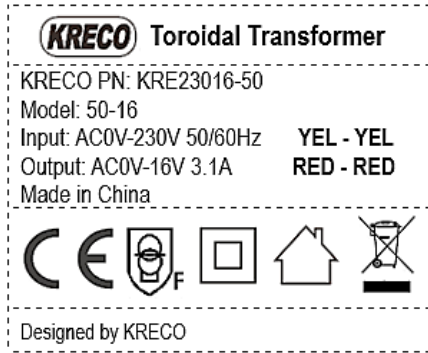

A MAX	B MAX
90	42

A: 85 (不含出线位)

绕组 WINDING	颜色 COLOUR	型号 TYPE	长度 LENGTH(mm)±10mm	端子 HOUSING(mm)
初级 PRI	黄 黄 YEL YEL	UL1015/18#	250	
次级 SEC	红 红 RED RED	UL1015/18#	250	

料号 MATERIAL NO.	制图 DRAWING	制样 SAMPLE	审核 CHECK	批准 APPROVE	日期 DATE
	张兰	张海平	李桂军		2023.03.24

顾客 CUSTOMER	140062	产品名称 DESCRIPTION	TRANSFORMER	
部品号 KRECO P/N	KRE23016-50	型号 MODEL	50-16	A版

## 2. 电原理图

### CIRCUIT DIAGRAM

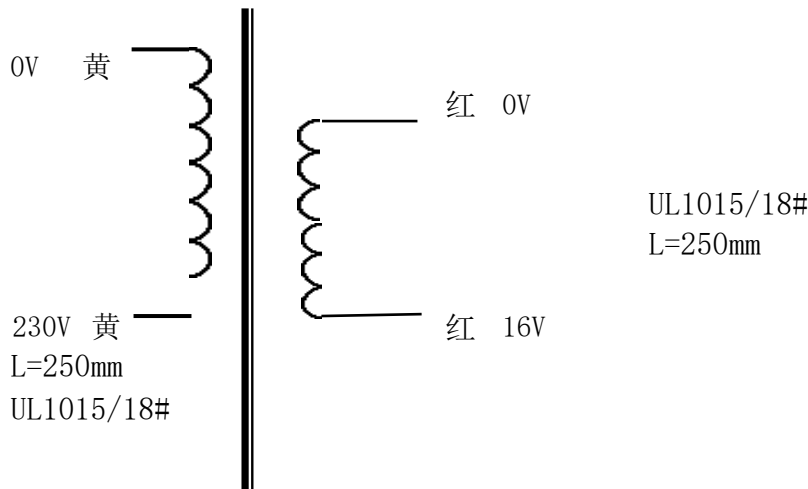

## 3. 电气特性

### ELECTRIAL CHARACTERISTIC

3.1	初级额定输入 Pri. Rating Input	AC230 50Hz 黄 黄			
3.2	初级空载电流 Primary Exciting Current	≤10mA MAX(At 230V 50Hz INPUT)			
3.3	次级电压 (初级额定输入) (Pri. Rating Input)	测量点 Measure Point	空载电压 No Loading Voltage	负载电压 & 电流 Loading Voltage & Current	
		红 红	RED RED	16VAC±5%	15VAC±5% 3.13A
3.4	抗电强度 Hi-Pot Test	初级-次级/PRI-SEC: AC 3.5KV 50Hz 3mA FOR 60S			
3.5	绝缘阻抗 Insulation Resistance	初级-次级/PRI-SEC: 100Ω MIN(AT DC 500V)			
3.6	温升 Temperature Rise	MAX(室温25℃,满负载4小时,温升85℃。电阻法测) (@25°C AFTER FULL LOAD WORKING 4 HOURS, 85°C Temperature Rise. RESISTER METHOD)			
3.7	端子强度 Terminal Strength	端子方向承受2KG拉力, 30秒, 无异常 2.0KG along the PIN direction 30 seconds ,no damage			

料号 MATERIAL NO.	制图 DRAWING	制样 SAMPLE	审核 CHECK	批准 APPROVE	日期 DATE
	张兰	张海平	李桂军		2023.03.24

顾 客 CUSTOMER	140062	产品名称 DESCRIPTION	TRANSFORMER	
部 品 号 KRECO P/N	KRE23016-50	型 号 MODEL	50-16	A版

4. 解剖图  
CONSTRUCTION DIAGRAM

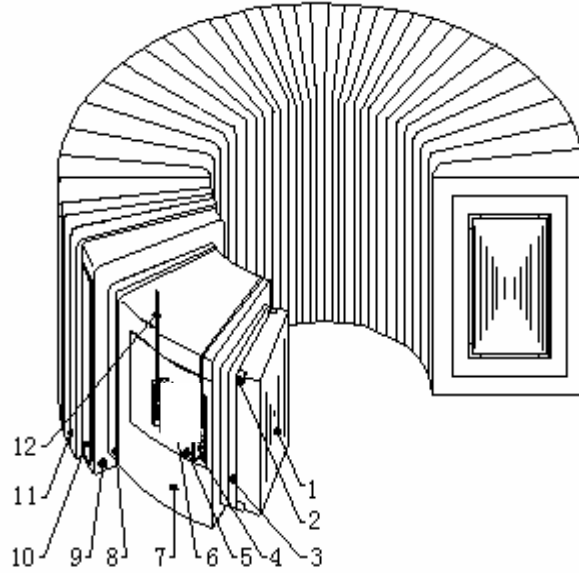

- |                        |                               |
|------------------------|-------------------------------|
| 1. CORE                | 8. OVER PRIMARY INSULATION    |
| 2. SLEEVE TUBE         | 9. SECONDARY WINDING          |
| 3. INSULATION FOR CORE | 10. PROTECTIVE TAPE           |
| 4. TIE-IN JACKET       | 11. OVER SECONDARY INSULATION |
| 5. TIE-IN MAT          | 12. PRI. LEAD WIRE            |
| 6.                     |                               |
| 7. PRIMARY WINDING     |                               |

5. 附件  
ACCESSORY

弹簧垫片 SPRING SHIM	M8×1.0t (镀锌)	1PCS	螺栓 SCREW	M8×55 (不含螺栓头) (镀锌)	1PCS
橡胶垫 RUBBER MAT	Φ60×Φ10.5×1.5t (BLACK)	1PCS	螺母 NUT	M8 (镀锌)	1PCS
	Φ70×Φ10.5×1.5t (BLACK)	1PCS			
环牛盖 COVER	Φ60×8.5×1.2	1PCS	平垫片 SHIM	M8×Φ15×1.5 (镀锌)	2PCS
插座 SOCKET			插座 SOCKET		

料 号 MATERIAL NO.	制 图 DRAWING	制 样 SAMPLE	审 核 CHECK	批 准 APPROVE	日 期 DATE
	张 兰	张 海 平	李 桂 军		2023.03.24