

顾客:  
CUSTOMER

140062

FILE NO: A版  
文件编号:



景荣企业有限公司  
中山市景荣电子有限公司

KINGRONG ENTERPRISE LTD. (Since 2008)

ZHONGSHAN KINGRONG ELECTRONICS CO., LTD.

样品承认书

SPECIFICATION FOR APPROVAL

产品名称 \_\_\_\_\_ 型号 \_\_\_\_\_  
DESCRIPTION TOROIDAL TRANSFORMER MODEL NO 80-16

顾客部品号 \_\_\_\_\_  
CUSTOMER'S PART NO.

制造商料号 \_\_\_\_\_ 日期 \_\_\_\_\_  
MANUFACTURE'S P/N. KRE23016-80 DATE 2023年3月24日

确认签字、盖章后请寄回此承认书一份  
PLEASE RETURN TO US ONE COPY OF "SPECIFICATION FOR APPROVAL " WITH YOUR APPROVED SIGNATURES

	"√"	顾客签名 CUSTOMER'S SIGNATURE	备注 NOTE
完全承认 FULL APPROVED			
有条件承认 CONDITIONAL APPROVED			
不予承认 REJECTED			

ZHONGSHAN KINGRONG ELECTRONICS CO.,LTD.

9/F,Block 2,Bldg 6 Meicheng Creative Industrial Park,Mingcheng East Rd,

Xiaolan,Zhongshan,Guangdong,528415 China

MOBILE:+86-13822715268 TEL:+86-760-22582166

EMAIL: SALES@KRECO.COM.CN

顾 客 CUSTOMER	140062	产品名称 DESCRIPTION	TRANSFORMER	
部 品 号 PART NO.	KRE23016-80	型 号 MODEL	80-16	A版

1. 外形图 (单位:mm)  
DIMENSION (UNIT:mm)

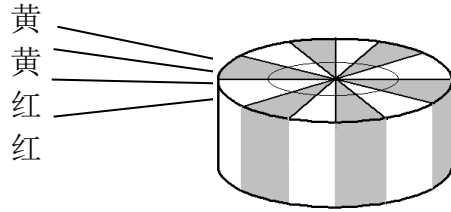

外包白色玛拉胶, 透明带。

LABEL:

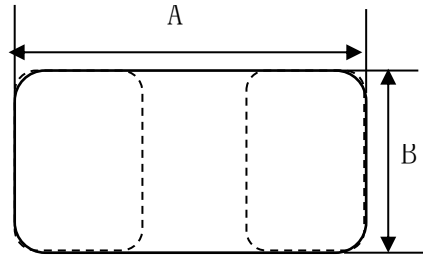
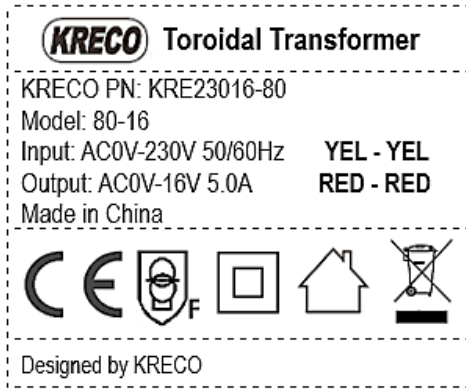

A MAX	B MAX
100	47

A: 85 (不含出线位)

绕组 WINDING	颜色 COLOUR	型号 TYPE	长度 LENGTH(mm)±10mm	端子 HOUSING(mm)
初级 PRI	黄 黄 YEL YEL	UL1015/18#	250	
次级 SEC	红 红 RED RED	UL1015/16#	250	

料 号 MATERIAL NO.	制 图 DRAWING	制 样 SAMPLE	审 核 CHECK	批 准 APPROVE	日 期 DATE
	张 兰	张 海 平	李 桂 军		2023.03.24

顾 客 CUSTOMER	140062	产品名称 DESCRIPTION	TRANSFORMER	
部 品 号 PART NO.	KRE23016-80	型 号 MODEL	80-16	A版

## 2. 电原理图

### CIRCUIT DIAGRAM

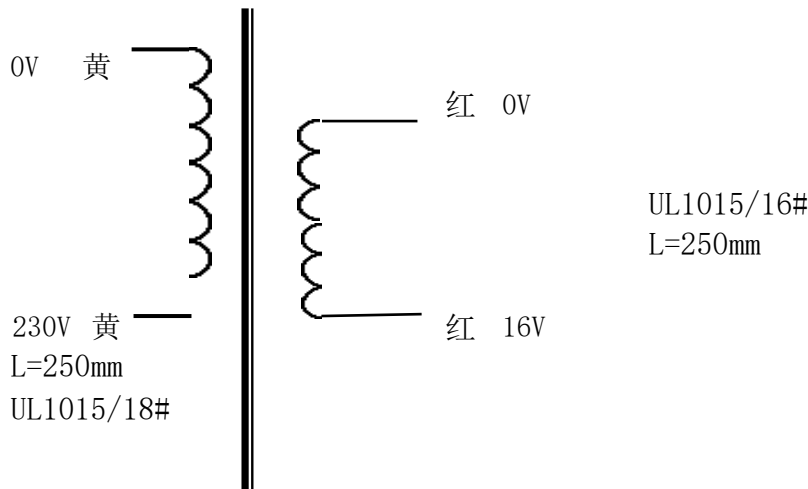

## 3. 电气特性

### ELECTRIAL CHARACTERISTIC

3.1	初级额定输入 Pri. Rating Input	AC230 50Hz 黄 黄			
3.2	初级空载电流 Primary Exciting Current	≤15mA MAX(At 230V 50Hz INPUT)			
3.3	次级电压 (初级额定输入) (Pri. Rating Input)	测量点 Measure Point	空载电压 No Loading Voltage	负载电压 & 电流 Loading Voltage & Current	
		红 红	RED RED	16VAC±5%	15VAC±5% 5A
3.4	抗电强度 Hi-Pot Test	初级-次级/PRI-SEC: AC 3.5KV 50Hz 3mA FOR 60S			
3.5	绝缘阻抗 Insulation Resistance	初级-次级/PRI-SEC: 100Ω MIN(AT DC 500V)			
3.6	温升 Temperature Rise	MAX(室温25℃,满负载4小时,温升85℃。电阻法测) (@25°C AFTER FULL LOAD WORKING 4 HOURS, 85°C Temperature Rise. RESISTER METHOD)			
3.7	端子强度 Terminal Strength	端子方向承受2KG拉力, 30秒, 无异常 2.0KG along the PIN direction 30 seconds ,no damage			

料 号 MATERIAL NO.	制 图 DRAWING	制 样 SAMPLE	审 核 CHECK	批 准 APPROVE	日 期 DATE
	张 兰	张 海 平	李 桂 军		2023.03.24

顾 客 CUSTOMER	140062	产品名称 DESCRIPTION	TRANSFORMER	
部 品 号 PART NO.	KRE23016-80	型 号 MODEL	80-16	A版

4. 解剖图  
CONSTRUCTION DIAGRAM

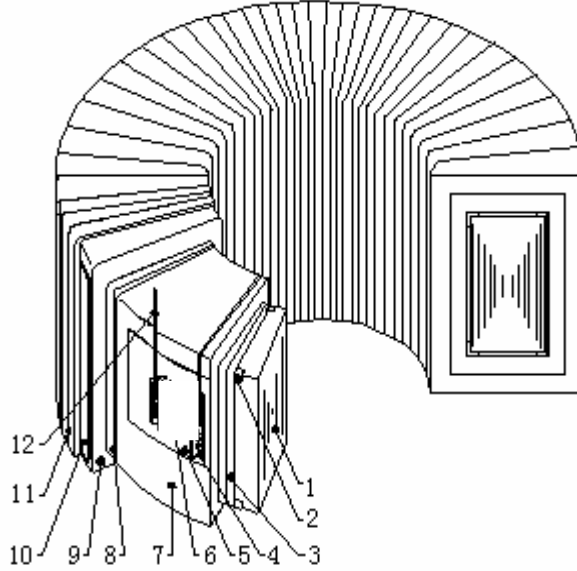

- |                        |                               |
|------------------------|-------------------------------|
| 1. CORE                | 8. OVER PRIMARY INSULATION    |
| 2. SLEEVE TUBE         | 9. SECONDARY WINDING          |
| 3. INSULATION FOR CORE | 10. PROTECTIVE TAPE           |
| 4. TIE-IN JACKET       | 11. OVER SECONDARY INSULATION |
| 5. TIE-IN MAT          | 12. PRI. LEAD WIRE            |
| 6.                     |                               |
| 7. PRIMARY WINDING     |                               |

5. 附件  
ACCESSORY

弹簧垫片 SPRING SHIM	M8×1.0t (镀锌)	1PCS	螺栓 SCREW	M8×60 (不含螺栓头) (镀锌)	1PCS
橡胶垫 RUBBER MAT	Φ70×Φ10.5×1.5t (BLACK)	1PCS	螺母 NUT	M8 (镀锌)	1PCS
	Φ80×Φ10.5×1.5t (BLACK)	1PCS			
环牛盖 COVER	Φ70×8.5×1.2	1PCS	平垫片 SHIM	M8×Φ15×1.5 (镀锌)	2PCS
插座 SOCKET			插座 SOCKET		

料 号 MATERIAL NO.	制 图 DRAWING	制 样 SAMPLE	审 核 CHECK	批 准 APPROVE	日 期 DATE
	张 兰	张 海 平	李 桂 军		2023.03.24